

REV :	DESCRIPTION :	BY :	DATE :
T1	PRELIMINARY	Neil Zeng	2014/03/19

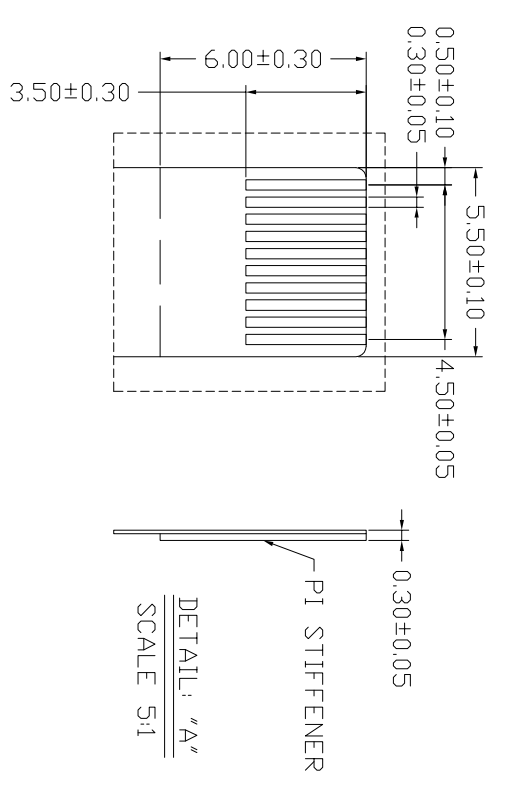

12C PIN TABLE

PIN#	12C
1	SCL
2	SDA
3	/RESET
4	/CHG
5	NC
6	GND
7	VDD(3.3V)
8	NC
9	NC
10	NC

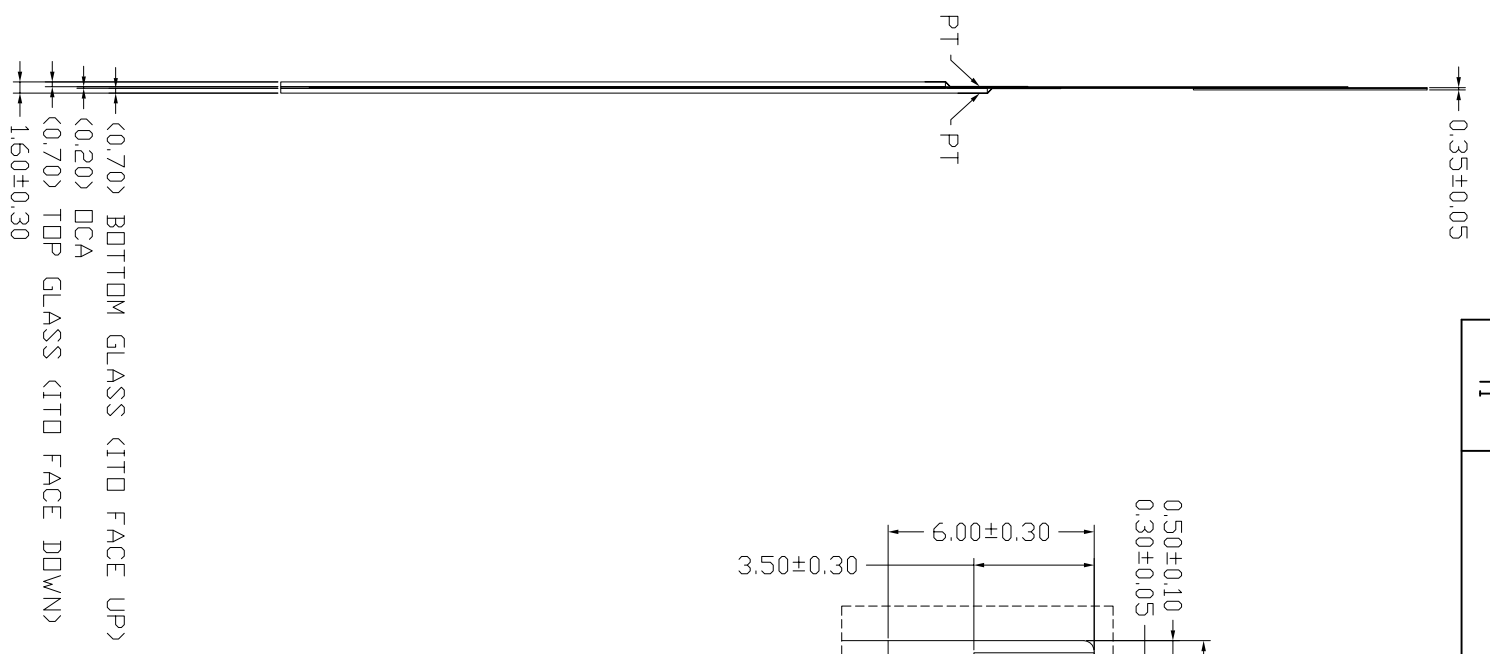

- 102.90 BOTTOM GLASS
- 96.80 TOP GLASS
- 88.40 VIEW AREA
- 86.40 ACTIVE AREA
- 5.90
- 4.90
- 6.00
- 5.00
- 115.20 ACTIVE AREA
- 117.20 VIEW AREA
- 125.90 BOTTOM GLASS
- 131.10 TOP GLASS

NOTES:

1. ALL DIMENSIONS IN MM.
2. OPERATING TEMPERATURE: -20°C TO 80°C
3. STORAGE TEMPERATURE: -30°C TO 80°C
4. FPC BENDING RADIUS IS R1.0MM MIN
5. ALL MATERIALS MUST BE ROHS COMPLIANT
6. FACE PLATE: SODA-LIME GLASS, NO SHARP CORNERS OR EDGES.
7. (*) DIMENSION FOR REFERENCE
8. THE COMPATIBLE MOLEX FPC CONNECTOR IS 52745-1097 OR EQUIVALENT

REGULAR
Display Your Advantage

THIS DOCUMENT IS CONFIDENTIAL, PROPRIETARY INFORMATION OF REGULAR CORPORATION AND SHALL NOT BE DISCLOSED OR COPIED OR USED FOR ANY PURPOSE OTHER THAN FOR WHICH IT IS SPECIFICALLY FURNISHED WITHOUT THE PRIOR WRITTEN CONSENT OF REGULAR CORPORATION.

UNLESS OTHERWISE NOTED :		ENGR MANAGER :	DATE :
UNITS	DECIMAL	CHECKED BY : Jacky Li	DATE : 2014/03/19
INCHES [mm]	.XXX[.XX] ±0.008[0.20]	D/WN BY : Neil Zeng	DATE : 2014/03/19
ANGLES	±0.5°	DRAWING TITLE : F057-0224S-194	
THIRD ANGLE PROJECTION		DRAWING No. : F057-0224S-194	REV : T1
SCALE	1 : 1	SCALE	1 : 1
		SHEET	1 OF 1